

Operation Manual

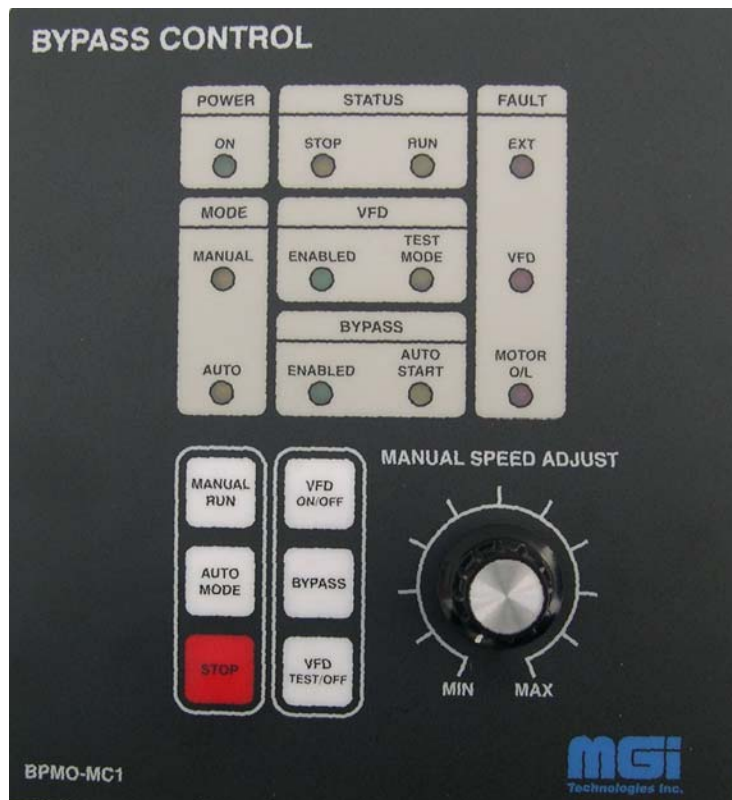

SWFI-A-01/00

WWW.mgitech.com
MGI Technologies Inc. 275 West 4th Ave, Vancouver, BC Canada

Features

1. Door Mounted Keypad Module.

Operator Controls			
Selected Key		Related Key	Function
MANUAL RUN	"ON"	VFD "ENABLED"	Run command applied to the VFD. Motor running at speed set by "MANUAL SPEED ADJUST" potentiometer.
		BYPASS "ENABLED"	Run command applied to the system. Motor operating at full speed in bypass mode.
		VFD TEST "ON"	VFD powered up and run command applied. Contactors on the output of the VFD open. VFD can be tested or fault investigated without power being applied to the motor. Output frequency can be set by "MANUAL SPEED ADJUST" potentiometer. Limited access to the software parameters of the VFD. Motor can operate in bypass mode while VFD is in the "TEST MODE"
AUTO MODE	"ON"	VFD "ENABLED"	VFD accepts command and frequency reference signal from BMS.
		BYPASS "ENABLED"	System accepts run command from the BMS. Motor running at full speed when run command applied.
		VFD TEST "ON"	VFD accepts command and frequency reference signal from BMS. Contactors on the output of the VFD open. VFD can be tested or fault investigated without power being applied to the motor. Output frequency is set by BMS. Motor can operate in bypass mode while VFD is in "TEST MODE"
STOP		VFD "ENABLED"	Run command removed from the system. VFD not outputting any power, motor not running. VFD can be fully programmed if the "Software lock" feature is not enabled.
		"BYPASS" key	Bypass "ON" LED lit. Motor not running.
		VFD TEST "ON"	Run command not applied to the VFD. Contactors on the output of the VFD open. VFD can be fully programmed if the "Software lock" feature is not enabled. Run command can be applied by pressing "MANUAL RUN" key and VFD can be tested without power being applied to the motor. Output frequency can be set by "MANUAL SPEED ADJUST" potentiometer if "MANUAL RUN" selected.
VFD	"ENABLED"	"MANUAL RUN "	Run command applied to the VFD. Motor running with speed manually set by "MANUAL SPEED ADJUST" potentiometer.
		"AUTO MODE"	VFD accepts run command and speed reference from the BMS.
		"STOP"	Run command removed from the VFD. VFD can be fully programmed if the "Software lock" feature is not enabled.
	"OFF"		VFD not powered up.
BYPASS	"ENABLED"	"MANUAL RUN "	Motor running at full speed in bypass mode.
		"AUTO MODE"	Motor running at full speed in bypass mode if run command applied by BMS.
		"STOP"	Motor not running. Bypass (3M) contactor open.
VFD TEST	"ON"	"MANUAL RUN "	Run command applied to the VFD. Contactor on the output of the VFD open. VFD can be tested without power being applied to the motor. Output frequency can be set by "MANUAL SPEED ADJUST" pot. Limited access to the software parameters of the VFD. Motor can operate in bypass mode while VFD is in "TEST MODE"
		"AUTO MODE"	VFD powered up. Contactor (2M) on the output side of the VFD open
		"STOP"	Run command not applied to the VFD. Contactor on the output of the VFD open. VFD can be fully programmed if the "Software lock" feature is not enabled. Run command can be applied by pressing "MANUAL RUN" key and VFD can be tested without power being applied to the motor. Output frequency can be set by "MANUAL SPEED ADJUST" potentiometer if "MANUAL RUN" selected.
	"OFF"		VFD not powered up.

Note: Full access to the VFD parameters while system running in bypass, can be obtained by removing run command with DS1-7 DIP switch. DIP switch has to be closed before switching to the VFD operation.

Diagnostic Indicator Lights		
Light	ON Status	
POWER	“ON”	When control power is applied to the Bypass Control Module
STATUS	“STOP”	When there is no “RUN” command to the bypass system due to: a. “STOP” command has been given through the keypad b. System in “AUTO” mode with no “RUN” command from the BMS
	“RUN”	When “RUN” command applied by pressing “MANUAL RUN” key or from BMS and motor running either in VFD or bypass.
MODE	“MANUAL”	System in “MANUAL RUN” mode. Run command applied and if in VFD mode motor speed can be set with “MANUAL SPEED ADJUST” potentiometer.
	“AUTO”	System in “AUTO” mode. Run command and speed reference accepted from BMS.
VFD	“ON”	System set to run motor from the VFD. “MANUAL” or “AUTO” mode can be selected.
	“TEST”	VFD in test mode.
BYPASS	“ON”	System in bypass mode
	“AUTO START”	System in bypass auto restart mode. This mode can be selected by DS1-BPAS DIP switch located on the power supply relay board. In case of VFD fault, system automatically switches motor operation to bypass mode and VFD switched to the “TEST MODE” When motor is operating in bypass auto start mode the “AUTO START” LED is flashing.
FAULT	“EXT”	When NC contact opens in the external fault input. Run command removed and motor can not operate either VFD or bypass mode.
	“VFD”	When VFD experiences a fault condition. Motor can be operated in bypass mode. If “” bypass “AUTO START” feature selected with DS1 DIP switch located on the PS Relay Board , system automatically will be switch to the bypass mode in case of VFD fault condition
	“MOTOR O/L”	Applies only to bypass operation. Bypass contactor not energized, motor not running. Fault condition must be corrected and O/L relay reset in order to run the motor. In VFD operation motor is protected by an electronic O/L relay built into the drive, which must be properly set during start-up as per VFD operational manual.

2. Power Supply Relay Board Module

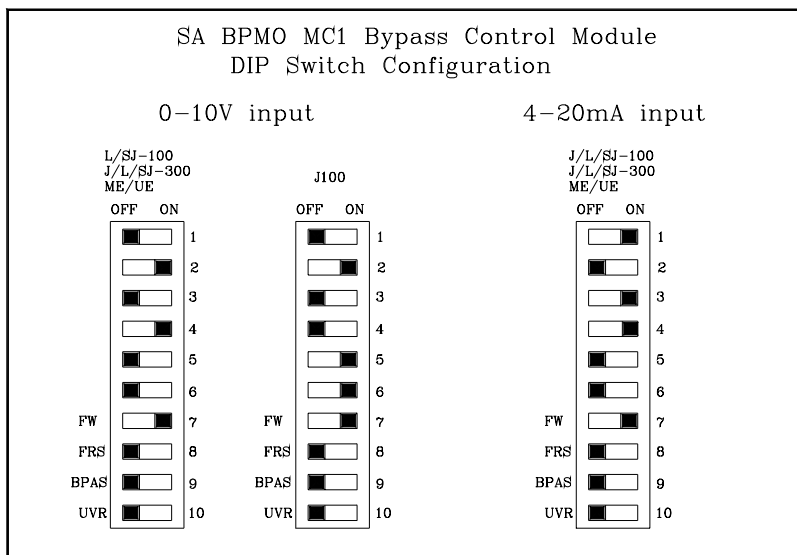

DS1 DIP switch is located on the power supply relay module board.

This switch is used to select type of the frequency reference for different drives as well as set some other functions as per following chart.

DS1 DIP Switch-Configuration Settings

DIP Switch #	Description
1 to 6	These settings allow the bypass system to accept 0-10V or 4-20mA frequency reference. With 0-10V setting the frequency reference signal from BMS must be connected to LS & VFS terminal. With 4-20mA setting the frequency reference signal from BMS must be connected to LS & CFS terminal.
7 (FW)	Run command circuit-switch closed during normal operation. With this switch VFD run command can be open to allow full access to the VFD parameters while system operating in bypass.
8 (FRS)	When selected, enables VFD to operate in free run stop (coast down) mode every time the run command is removed.
9 (BPAS)	When selected enables bypass "AUTO START" feature, which automatically switches system from VFD to bypass operation and sets VFD into the "TEST MODE". After the drive fault is cleared, system can be manually switched back to the VFD operation by selecting "VFD ON/OFF" key.
10 (UVR)	Selecting this feature will allow resetting the VFD every time drive is powered up.

Interconnection

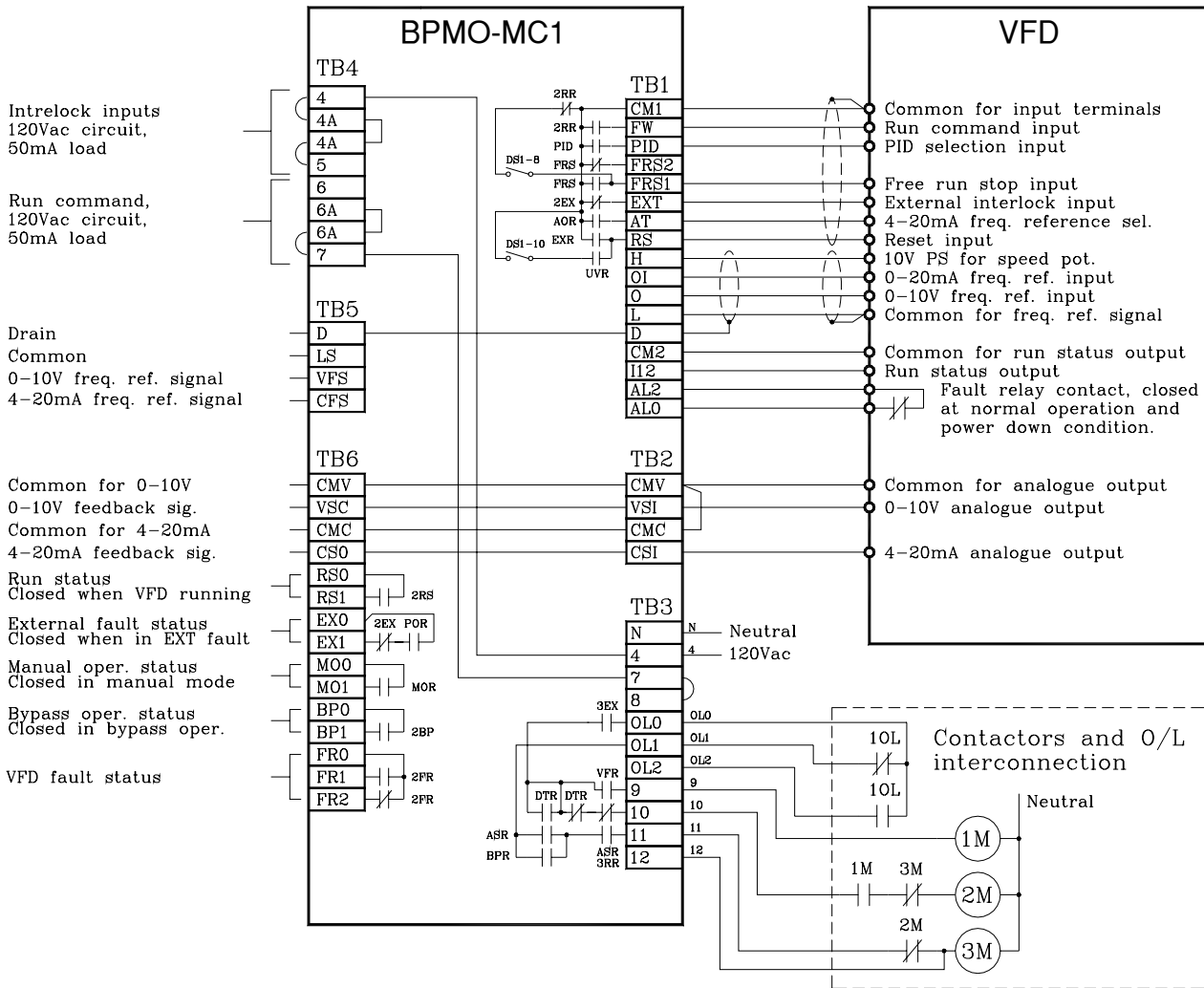

Note: Status contact circuit is rated at 5A/120Vac & 5A/30Vdc